

## PANEL5000-C2383-L

### ■ Features

- ◆ 23.8" FHD TFT
- ◆ Multipoint capacitive touch screen
- ◆ Supports 12 ~24V DC power input
- ◆ Fanless design, front panel IP65 compliant
- ◆ Supports panel mounted and VESA mounted

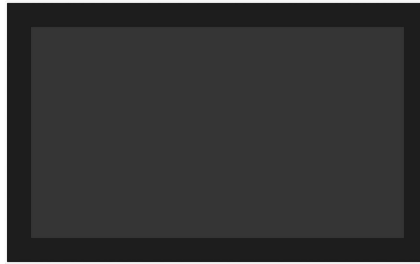

### ■ Specifications



Model Name		PANEL5000-C2383-L
Interface	Control button	Set Contrast ratio and Luminance via OSD at the back panel
	Signal input	1 x VGA /1 x HDMI
	USB	2 x USB2.0 / 1 x USB-B (Touch)
	DC IN	1 x DC IN
LCD	LCD Size	23.8" FHD TFT
	Resolution	1920 x 1080
	Luminance	300cd/m2
	MTBF	30000hrs
	Contrast Ratio	1000 : 1
Touch screen	Viewing Angle	(L) 89 / (R) 89 / (T) 89 / (B) 89
	Type	Multipoint capacitive touch screen
	Transmittance	≥ 87%
OS Support	Controller Interface	USB 2.0 Type B
	Microsoft Windows	Windows10, Linux
Power	Input voltage	DC 12~24V
	Maximum Power	<40Watt
Chassis	Structure	Front panel: aluminum-magnesium alloy, anodized coating ;Back over: SGCC, Ground isolation protection
	Mounting	Support panel mounted, wall-mounted, Desktop (VESA 75x75 & 100x100)
	Dimensions (W x H x D)	602.8mm x 372.2mm x 47mm
	Cut Out Size (W x H )	586mm x 355mm
	Net Weight	-kg
Environment	Work Temperature	0 ~ 50°C
	Storage Temperature	-20 ~ 60°C
	Relative Humidity	5~95% @40° (non-condensing)
	Vibration	SSD applied:1.5Grms, IEC 60068-2-64, random, 5~500Hz, 1 hr/axis
	Shock	SSD applied:10G, IEC 60068-2-27, Half sine wave, lasting 11ms
EMC	CE/FCC Class B	

## ■ Dimensions: Unit: mm

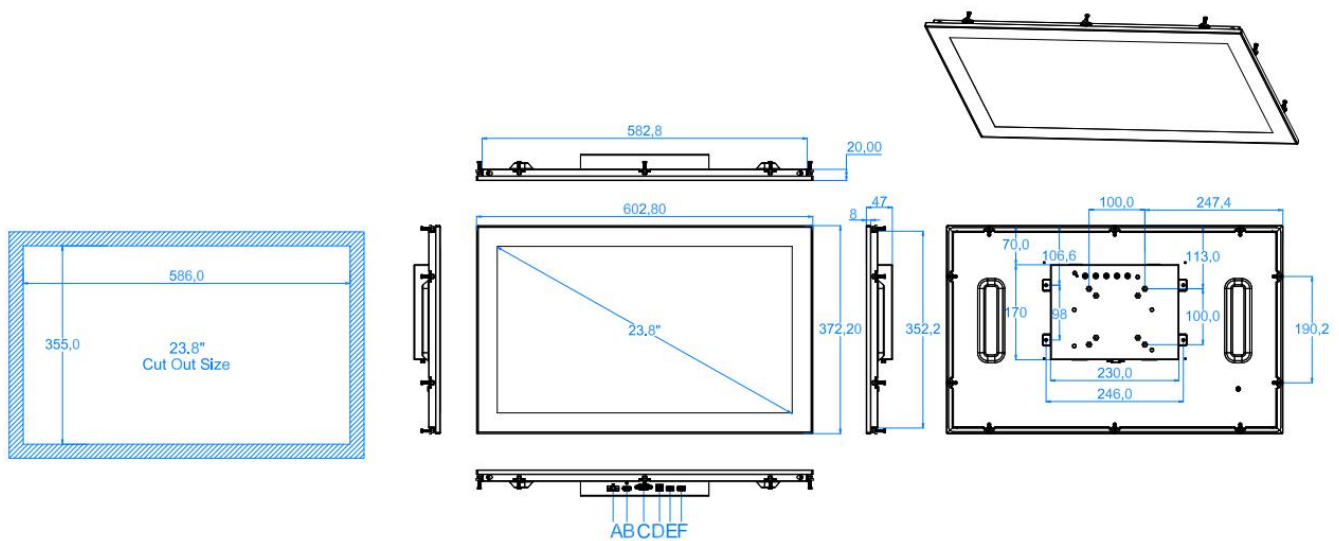

A: DC IN	B: HDMI	C: VGA	D: USB for TOUCH	E: USB	F: USB
----------	---------	--------	------------------	--------	--------

## ■ Ordering Information:

Model Name	Description
PANEL5000-C2383-L	23.8" LCD /1920×1080 /1×VGA /1×HDMI /Multipoint capacitive touch screen /2×USB /DC 12-24V input

## ■ Option Items:

Packing List	Description	Option Items	Description
Mounting screws	4*pcs Thickness=1mm~1.2mm	Adapter	12V/3.33A, 40W 2pin Phoenix terminal
Terminal	2pin Phoenix terminal	Power Cord	1.8M/ 3M /5M
VGA Cable	1.8M	VGA Cable	3M /5M
USB Cable	1.8M	USB Cable	3M /5M
		DVI Cable	1.8M /3M /5M

Note: If the system provides some optional parts, additional certification of system compatibility may be required in some regions/countries, please contact NODKA for system compatibility.